

Operation Manual for Heat Exchanger

Soul  Steel
Grill'D®

Please, read this Manual carefully prior to commencing the heat exchanger installation and operation!



Heat exchanger for heaters Grill'D Cometa 180 Vega

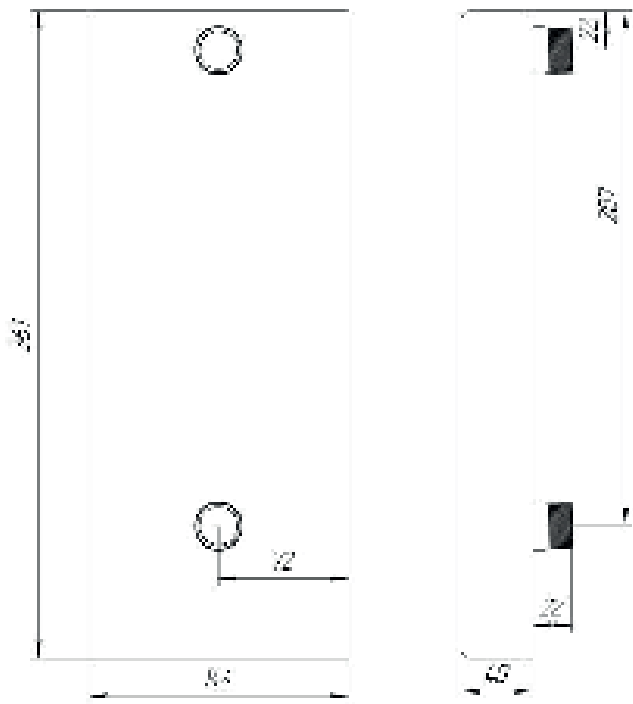

Fig. 1 Heat exchanger for heaters Grill'D Cometa 180 Vega

1. APPLICATION

Suspended heat exchanger is designed to provide hot water in a room equipped with a heater, or in a premise adjacent to it.

2. PACKAGE CONTENTS

Heat exchanger – 1 piece

Operation Manual - 1 piece

3. DESIGN AND OPERATING PRINCIPLE

Heat exchanger is a leaktight flat tank of a rectangular shape with a volume of 1.8 l.

It is installed on one of the heater firebox walls in order to accumulate the heat via transferring heat energy from the firebox wall to a closed water loop.

It is recommended to use with a suspended oval tank.

You will need to remove 3-4 lamellae (Fig.2) to mount the heat exchanger onto the heater.

To fix the heat exchanger at the place of installation, it is necessary to put stones into the outer stone heater, while pressing the heat exchanger tightly to the surface of the inner stone heater.

A graphic illustration of the hot water system is shown in Fig. 3

4. TECHNICAL DATA

<i>Name</i>	<i>Volume, l</i>	<i>Material, thickness</i>	<i>Diameter of connection fittings</i>
Heat exchanger	1.8	2 mm HRS*	3/4 " (25.4 mm)

* **HRS** for heat-resistance steel

• *Minimum water pressure upstream of the heat exchanger is 0.06 MPa (0.6 kgf/cm²);*

• *Maximum heating temperature is 95°C*

5. Protective MEASURES

IMPORTANT! THE FOLLOWING IS PROHIBITED DURING INSTALLATION AND OPERATION OF THE HEAT EXCHANGER:

- Installing it in places that do not comply with fire safety measures;
- Using the heat exchanger for arrangement of a heating system;
- Making changes in the design, use the Product for other purposes;
- Operating the tanks without filling them up with water;
- Using water with a high content of salts, iron, lime and other impurities that do not meet the standards ($\text{pH} > 7$);
- Leaving water in the heat exchanger at any time of the year;
- Operation without installation of a hot water system.

6. INSTALLATION AND PRESTARTING PROCEDURES

Installation of the heat exchanger, hot water system shall be carried out by a licensed company and competent specialists.

Prior to commencing installation, remove the protective film (if any), stickers, packaging elements, etc.

Check the Product for tightness via filling it up with water.

Rinse the internal area thoroughly with running water before use.

Follow local regulations, including those referring to the national standards, during installation and operation.

7. OPERATION AND MAINTENANCE PROCEDURE

Fill the system up with water, ignite the firebox of the bath house heater. As the heater is being stoked, you will be provided with hot water. If additional volume of hot water is necessary in the process of bathing and other activities, add cold water to the system and stoke the heater for the required period of time.

It is necessary to periodically clean the tanks from accumulated blockages and wash them with running water, at least once every 6 months.

In case of increase of the water heating time, as well as during long-term operation, check the connecting pipes for blockages and scaling. Remove the blockages and scaling, if any.

Rust, salt deposits, and scaling can form during operation under the influence of various external factors.

8. WARRANTY

OOO Sferra guarantees proper operation of the heat exchanger subject to the requirements for installation and operation described in this Manual. The warranty period is 12 months from the date of sale.

IMPORTANT! HEAT EXCHANGERS AS FOLLOWS SHALL NOT BE ACCEPTED FOR GUARANTEED REPAIR SERVICES:

- Without Operation Manual stamped by the retailer with an indication of the sale date;
- Damaged due to the Consumer's fault;
- After non-guaranteed repair services

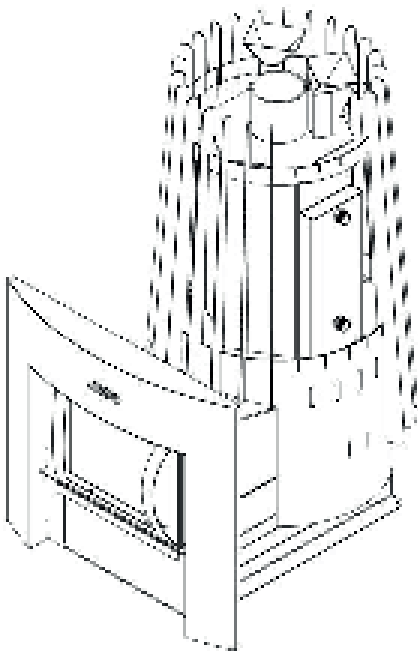

Fig. 2 Heat exchanger installation

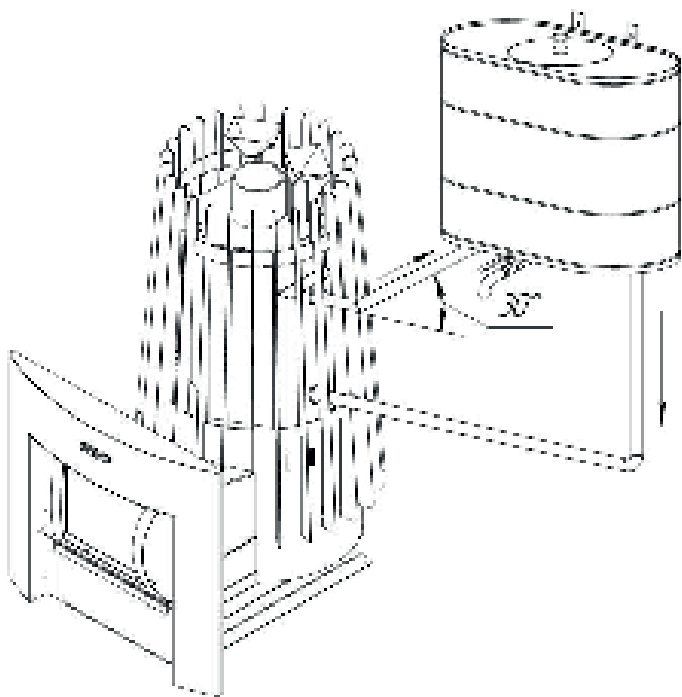
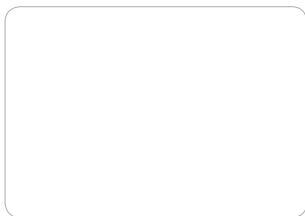

Fig. 3 *System installation*

CE

EAC



QCD mark: _____
(Name, signature, stamp)

Date of sale: _____
(Date, Seller's signature, store stamp)

I have read and understood this Operation Manual: _____
(Buyer's signature)

IMPORTANT! The Manufacturer disclaims warranty liability in the absence of a store stamp.